

MODEL	WORK SPACE W x D x H	KW	BTU/HR	CFM	MOTOR H. P.	INSULATION THICKNESS	"A"	"B"	"C"	"D"	"E"	"F"	"G"	"H"	"J"
HB-1050	38" x 26" x 38"	30	175,000	1600	1 1/2	10"	70"	17 1/4"	87 1/4"	46"	5"	51"	80 1/2"	23"	13"
HB-1250	38" x 26" x 38"	40	200,000	1600	1 1/2	12"	74"	17 1/4"	91 1/4"	50"	5"	55"	84 1/2"	25"	15"

OPTIONAL POWERED FORCED EXHAUSTER DIMENSIONS

MODEL	130 CFM				325 CFM				650 CFM			
	"K"	"L"	"M"	"N"	"K"	"L"	"M"	"N"	"K"	"L"	"M"	"N"
HB-1050	20 1/2"	18 1/2"	20 1/2"	4"	20 1/2"	16 1/2"	27"	6"	22"	16 1/2"	27"	6"
HB-1250	22 1/2"	20 1/2"	20 1/2"	4"	22 1/2"	18 1/2"	27"	6"	24"	18 1/2"	27"	6"

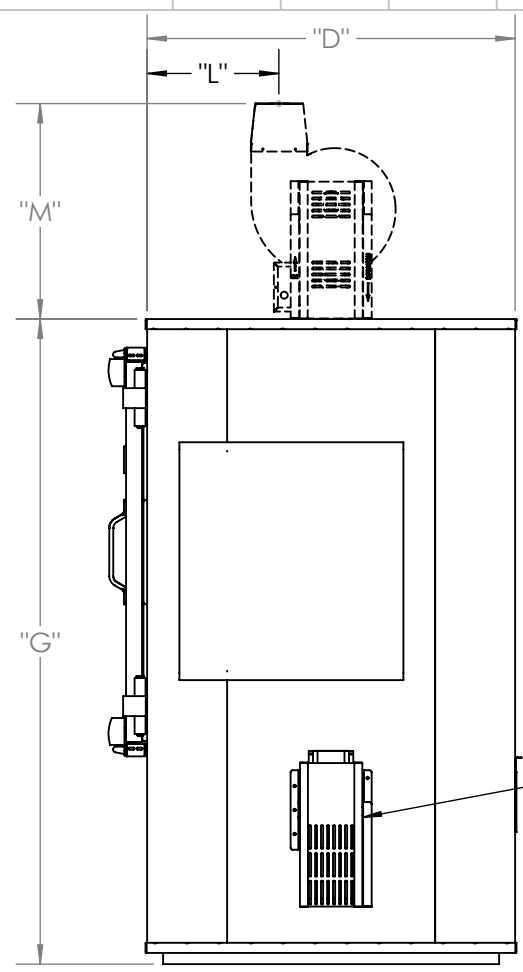
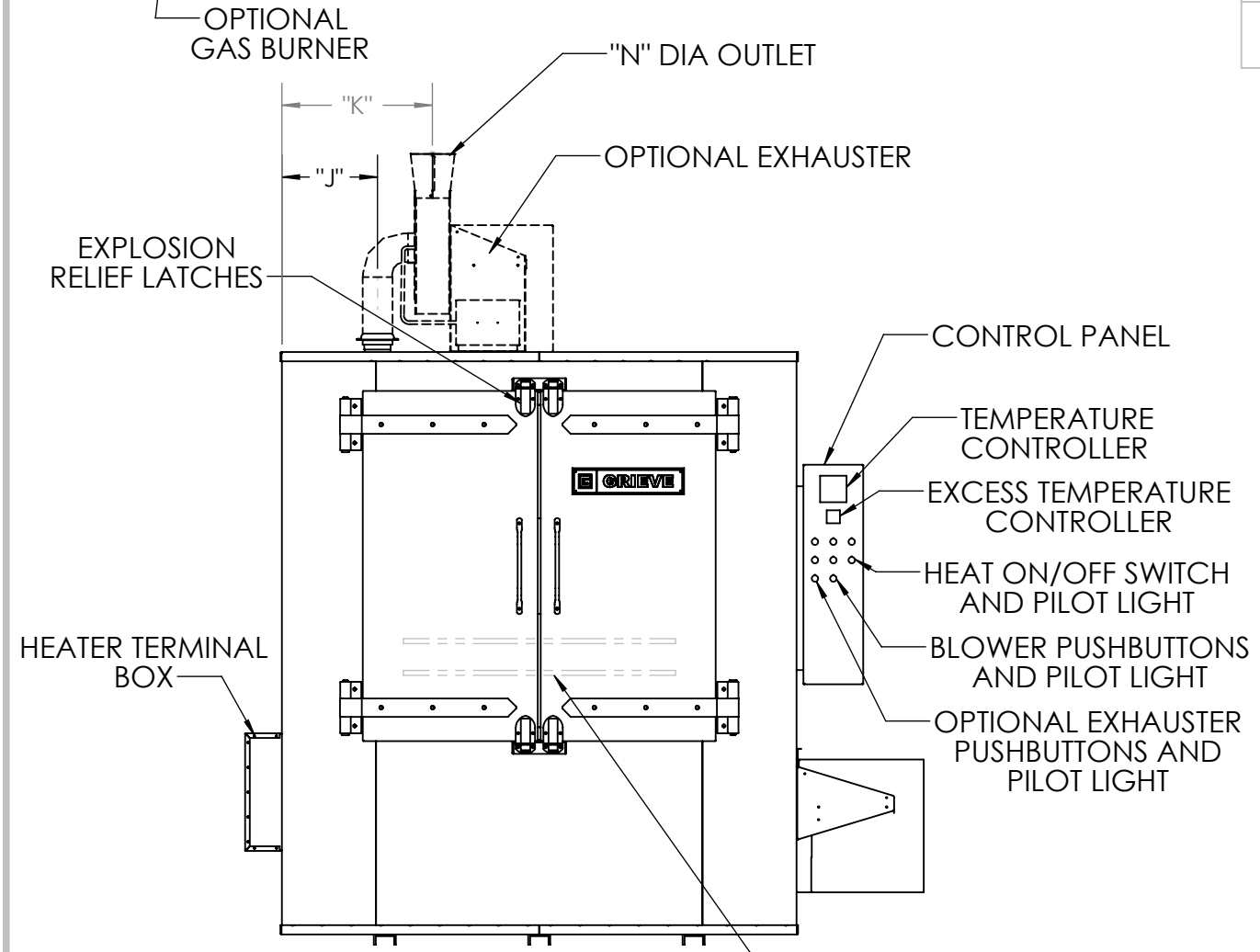

- NOTE
- STANDARD ELECTRICAL SERVICE: 208/3/60, 230/3/60, 460/3/60
  - STANDARD GAS SERVICE: 1,000 BTU NATURAL GAS AT 6" - 8" W.C. PRESSURE. OTHER GAS SERVICE ALSO AVAILABLE
  - AIR FLOW: HORIZONTAL
  - INTERIOR: 304 STAINLESS STEEL, WITH STAINLESS STEEL BLOWER WHEEL
  - EXTERIOR: ALUMINIZED STEEL, PAINTED TRILITE GREEN MACHINERY ENAMEL
  - GAS OVENS INCLUDE 325 CFM EXHAUSTER

(2) 200 LB. CAPACITY STAINLESS STEEL SHELVES SUPPLIED

This drawing is the property of THE GRIEVE CORPORATION, and may not be used or reproduced without the express permission of THE GRIEVE CORPORATION

REV.	DESCRIPTION	BY	DATE
	DESCRIPTION		
	CUSTOMER		
	MODEL	HB-1050, HB-1250 HIGH TEMPERATURE CABINET OVENS	
	SHOP ORDER		
	DRAWN BY	JC	DWG. NO.
	DATE		HB-1050
	PRINT DATE	7/9/2013	HB-1250